

Instructions for Replacing the Bearing Frame Assembly or Pump Shaft

Installation, Operation, & Service Instructions

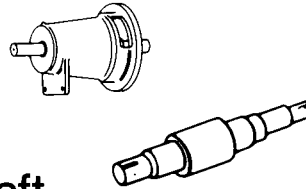

For 1510 or 3510 Pumps with 1¼" Diameter Standard Seal

INSTALLER: PLEASE LEAVE THIS MANUAL FOR THE OWNER'S USE.

SAFETY INSTRUCTION

This safety alert symbol will be used in this manual to draw attention to safety related instructions. When used, the safety alert symbol means ATTENTION! BECOME ALERT! YOUR SAFETY IS INVOLVED! FAILURE TO FOLLOW THE INSTRUCTIONS MAY RESULT IN A SAFETY HAZARD.

SERVICE INSTRUCTIONS

WARNING: Unexpected Start-up Hazard
Disconnect and lock out power before servicing. Failure to follow these instructions could result in serious personal injury or death and property damage.

1. Close valves on suction and discharge sides of the pump. (If no valves have been installed, it will be necessary to drain the system.)

CAUTION: Extreme Temperature Hazard
Allow pump temperatures to reach acceptable level before proceeding. Open drain valve, do not proceed until liquid stops flowing out of drain valve. If liquid does not stop flowing from drain valve, isolation valves are not sealing and should be repaired before proceeding. After liquid stops flowing from drain valve, leave valve open and continue. Remove the drain plug located on the bottom of the pump housing. Do not reinstall plug or close drain valve until reassembly is completed. Failure to follow these instructions could result in property damage and/or moderate personal injury.



2. Remove coupler guard. Loosen set screws in both coupler halves and slide each half back as far as possible on its shaft. Remove coupler sleeve. Where a full diameter impeller is used, it may be necessary to remove the pump coupler half and slide the motor back on its base in order to gain sufficient clearance to remove the pump assembly from the volute.
3. Remove support foot capscrews. Loosen volute capscrews, but do not remove. Begin to remove the pump assembly from the volute by placing capscrews in the jack screw holes for leverage.

WARNING: Excessive Pressure Hazard
Make certain internal pressure is relieved before continuing. Failure to follow these instructions could result in serious personal injury or death, and property damage.

4. Remove flushing tube, if any. Remove the volute capscrews, and remove the pump assembly from volute.
5. Remove the impeller capscrew, lockwasher, washer and impeller.
6. Remove the rotating portion of the seal, using a screwdriver, if necessary, to loosen the rubber ring.
7. Remove the seal insert, insert gasket and insert retainer (if used).

8. Remove the bearing frame capscrews and dislodge the bearing assembly from the coverplate (1510 only). If the bearing frame assembly is being replaced, skip to step 15. If replacing the shaft, continue to step 9.
9. Remove the grease fitting from the bearing cap (1510 only).
10. Remove the bearing cap capscrews and lift out the bearing cap and the shaft assembly.
11. Press the ball bearings off the shaft by pressing the inner race only. If a press is not available, a drift pin may be used to force the bearings off of the shaft. Ideally, old bearings should be replaced, or at least regreased (see page 4 for lubrication instructions) before installing on the new shaft.
12. Press the new or regreased ball bearings on the shaft, shield-side first, as far as they can go. Replace spring washer and place shaft assembly into bearing frame.
13. Remove any oil or dirt from new shaft and sleeve. Use Loctite retaining compound (included with shaft and sleeve) to coat the entire sleeve area of the shaft. Slip on sleeve and rotate to distribute Loctite compound evenly. Allow to set for 10 minutes before re-assembling the pump. Remove any excess Loctite compound.
14. Reinstall the bearing cap. Fasten bearing cap capscrews and tighten per torque chart below. Place the water slinger on the shaft, leaving approximately 1/8" between the slinger and the bearing cap. Fasten grease fitting into bearing cap (1510 only).
15. Mount the bearing frame assembly onto the coverplate (if required) and tighten the bearing frame capscrews (per torque chart).
16. Thoroughly clean the coverplate seal cavity and inspect for surface damage such as pitting, corrosion, nicks or scratches. Replace the coverplate if necessary.
17. Lubricate the shaft sleeve and coverplate seal cavity with soapy water. DO NOT USE PETROLEUM LUBRICANT. Install a new cup gasket and a new seal insert with indentation side down into the cup.
18. Slide a new rotating seal assembly onto the shaft sleeve. Using a screwdriver, push on the top of the compression ring until the seal is tight against the seat insert. Install seal spring. Install spring retainer (3510 only).
19. Install impeller, impeller washer, lockwasher and capscrew. Tighten capscrew per torque chart below.
20. Scrape all particles of old volute gasket off volute and coverplate surfaces and replace with new gasket (1510 pumps)*. Remove and replace coverplate O ring on 3510 pumps. Install pump assembly into volute and tighten volute capscrews per torque chart. Install seal flushing tube (if used). Install support foot capscrews and tighten per torque chart.
21. Install coupler and align, following directions on page 4. Install coupler guard and drain plug and close drain valve.
22. Open isolation valves and inspect pump for leaks. Return pump to service.

⚠ WARNING: Rotating Components Hazard
Do not operate pump without all guards in place. Failure to follow these instructions could result in serious personal injury or death and property damage.

Capscrew Type	Head Marking	CAPSCREW TORQUE (FOOT-POUND)					
		Capscrew Diameter					
		1/4	3/16	3/8	7/16	1/2	5/8
SAE Grade 1 & 2		3	6	10	16	24	46
Stainless Steel							
SAE Grade 5		8	17	30	50	76	148

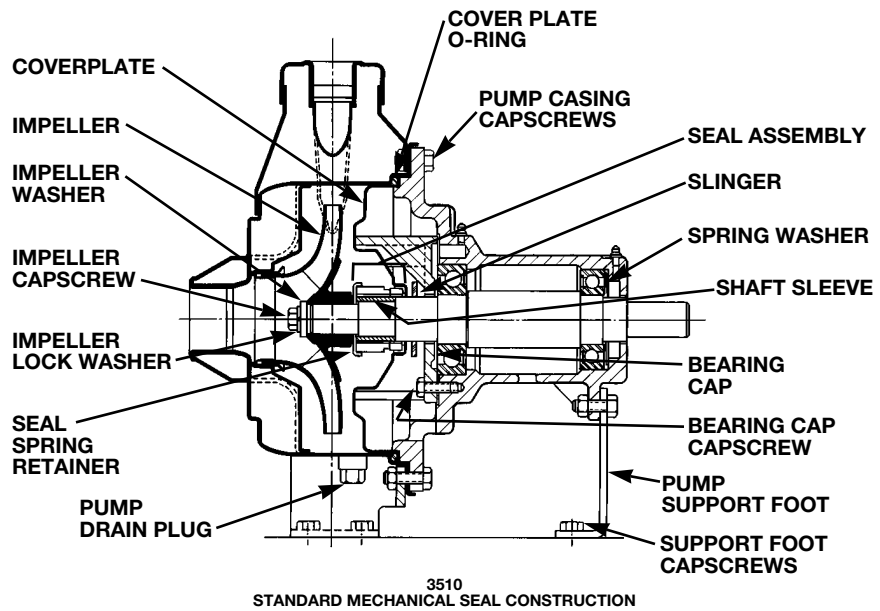
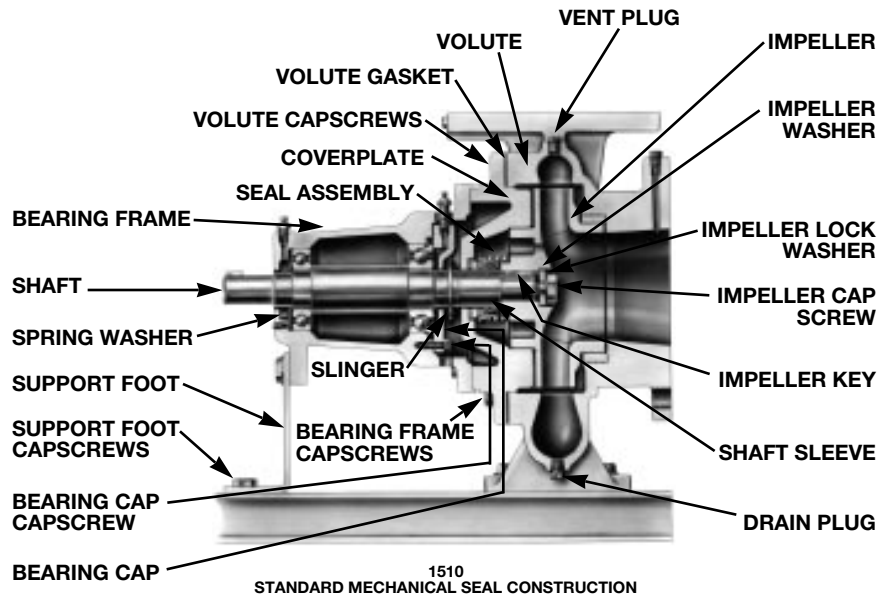

NOTE: To assure continued quality performance, use only genuine Bell & Gossett replacement parts

LUBRICATION INSTRUCTIONS

While pump is running regrease pump bearings with #2 lithium base petroleum grease after every 2500 hours of operation or every 6 months whichever occurs first.

Lubricate motor per motor manufacturer's instructions.

ALIGNMENT OF SLEEVE TYPE COUPLERS

Before aligning the coupler, make sure that there is about $\frac{1}{8}$ " end clearance between the sleeve and the two coupler halves.

Rubber and Hytrel sleeves should not be interchanged as they have completely different ratings relative to motor horsepower.

To align sleeve type couplers:

1. Parallel alignment must be made with a straight edge across the two coupler flanges at four points 90° apart. DO NOT ROTATE COUPLER.

2. Angular alignment must be checked with a micrometer or caliper, measure from the outside of one flange to the outside of the other flange at four points 90° apart. DO NOT ROTATE COUPLER.

All alignment should be done by moving or shimming the motor only. Adjustments in one direction may alter alignment in another. Therefore, check alignment in all directions after a correction is made.

If couplings are to operate at speeds higher than 1800 RPM, greater accuracy of shaft alignment will be required. A dial indicator should then be used.

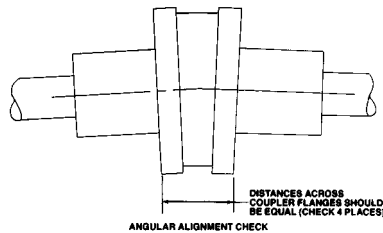
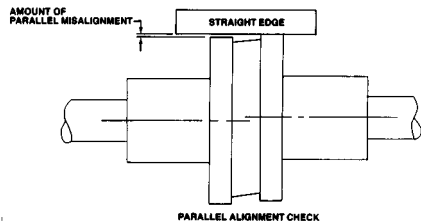

WARNING: Rotating Components Hazard
Do not operate pump without all guards in place. Failure to follow these instructions could result in serious personal injury or death and property damage.

For further information, contact ITT Bell & Gossett, 8200 N. Austin Avenue, Morton Grove, IL 60053, Phone (847) 966-3700 – Facsimile (847) 966-9052.